



The Behavior of Concrete Columns Reinforced with FRP Bars Instead of Steel Rebar

F. Danesh^{1*}, B. Baradaran N.²

1- Associate professor, Department of Civil Engineering, KNT University of technology, Tehran, Iran

2- MSc Student, Department of Civil Engineering, KNT University of technology, Tehran, Iran

(Received 23 Feb 2010, Accepted 19 Apr 2014)

ABSTRACT

Using FRP material, due to their excellent features like high strength to weight ratio, resistance to corrosion, convenience of transportation and installation, is developing rapidly. Using FRP bar instead of steel rebar significantly prevents corrosion in concrete members specifically for the seashore concrete structures.

In this research, in order to investigate the benefits of replacing steel rebar with FRP bars in concrete columns, some column specimens were modeled in finite element computer program and the effects of parameters like FRP bar ratio and compressive strength of concrete on the flexural capacity and ductility of column were discussed. The investigations on the concrete columns strengthened with CFRP bar and steel rebar, indicate that the FRP bar ratio is significantly less than the steel rebar ratio to achieve the acceptable strength.

KEYWORDS

Concrete Column, FRP bar ratio, Compressive Strength of Concrete, Flexural Capacity, Flexibility.

* Corresponding Author, Email: danesh@kntu.ac.ir

1- INTRODUCTION

Near surface mounted (NSM) technique was successfully used to upgrade the flexural capacity of the reinforced concrete (RC) piers. Flexural strengthening and testing to failure of the piers were carried out on a bridge that was scheduled for demolition during the spring of 1999. Three of the four piers of the bridge were strengthened with different configurations using FRP rods and jackets. The flexural strengthening was achieved using NSM carbon FRP rods that were anchored into the footings [1].

The first systematic study on NSM-based flexural strengthening of RC columns under simulated seismic loading was presented by Bournas and Triantafillou [2]. Their investigation addressed the column strengthening with NSM carbon or glass fibers, as well as stainless steel rebars. Another innovative aspect in that study was the combination of NSM reinforcement with local jacketing, which comprised the recently developed textile-reinforced mortar (TRM) confining system, described by Triantafillou et al. (2006) and Bournas et al. (2007) [3-4].

The obtained experimental results from a recent study By Barros et al. (2008) involved strengthening RC columns with NSM CFRP strips indicate that the proposed strengthening technique is very promising for increasing the load carrying capacity of the concrete columns failing in bending.[5]

This paper will review the research conducted on replacing steel rebar with CFRP bars in the concrete columns to prevent corrosion phenomenon. In order to reach this goal, a three dimensional model of column reinforced with CFRP bar subjected to monotonic lateral with constant axial compressive load was modeled in the finite element program and the results obtained from the analysis are compared to the results of experimental work on the same specimen [6]. After the verification of analytical and experimental results, steel reinforcement in the concrete columns are replaced by CFRP bar and the effect of parameters such as longitudinal CFRP reinforcement ratio and concrete strength on the base shear force and ultimate displacement of columns were then investigated. Afterward, the equivalent CFRP bar ratio needed to replace steel rebar to reach the same column strength was found.

2- SPECIMENS MODELING IN FINITE ELEMENT PROGRAM

In order to investigate the accuracy of the analytical model, a three dimensional model of a concrete column with cross section of 400 cm^2 (20x20cm), which was reinforced by CFRP bars, was created in the finite element program and the force-displacement curves obtained from the analysis were compared to the results obtained from the experimental work on the same specimen[6]. Afterward, the columns with cross sectional dimensions of 40x40cm, in which steel rebar were replaced by CFRP bar, were modeled in computer program and their behavior under axial and lateral load were studied. The geometry, element properties, material

specifications, loading and boundary condition are explained in the following sections.

2-1- GEOMETRY OF SPECIMENS

Geometry of the column, which was verified by experimental observation, is depicted in Figure 1 and Figure 2. This column was strengthened with four NSM CFRP bars (with diameter of 12mm) at each side of it.

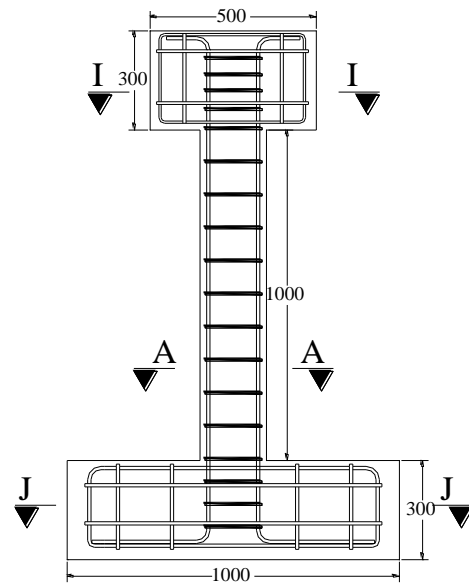

Figure1. Geometry of modeled specimen (dimensions in mm).

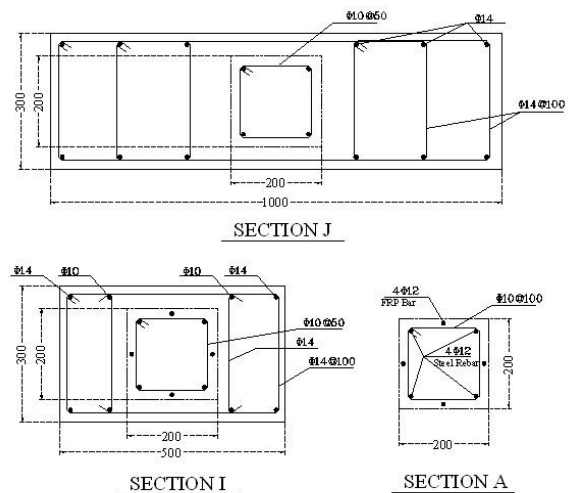

Figure2. Cross sections of cap beam, column and foundation (dimensions in mm)

The column specimens are designed to investigate the effects of replacing steel rebar with CFRP bars have cross sectional dimensions of 40x40cm and were reinforced with CFRB bars and steel stirrups. The stirrups were arranged such that all FRP bar are placed in the corners. Figure 3 shows the cross section of the specimens

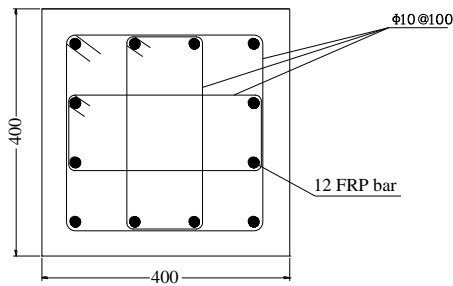

Figure3. Cross sections of column specimens (dimensions in mm)

2-2- ELEMENT PROPERTIES AND MATERIAL SPECIFICATIONS

According to the three-dimensional modeling of the specimens, the column, foundation and cap beam were modelled with 3D continuum elements (8-node linear brick element - C3D8). Rebar and stirrup were modelled using truss elements (3-node quadratic displacement elements - T3D2) which were embedded in the concrete elements.

The material properties used in this study are summarized in Table 1.

Table1. Summary of material properties

Concrete	Compressive strength	20
	Mpa	
Steel	Yield strength	400
	MPa	
	Elasticity modulus	
CFRP rebar	MPa	200000
	Tensile strength	
	MPa	
	Elasticity modulus	
	MPa	72
	GPa	
	Ultimate strain	1.7

2-3- BOUNDARY CONDITION AND LOADING

Foundation and cap beam of the specimen with cross sectional dimensions of 20x20cm, were also modeled to approximate boundary condition and loading of the experimental work.

A constant axial compressive load of 200 kN (which corresponds to an axial load ratio of 0.25) was applied on the top elements of cap beam in the area of 200x200 mm. This was followed by a monotonic lateral displacement load applied to the cap beam.

For the parametric study, specimen columns with cross sectional dimensions of 40x40 cm, were modeled and the bottom elements of columns restrained in all degrees of freedom. Constant axial compressive load of 800 kN (which corresponds to an axial load ratio of 0.25) and monotonic lateral displacement load were applied on the top elements of columns.

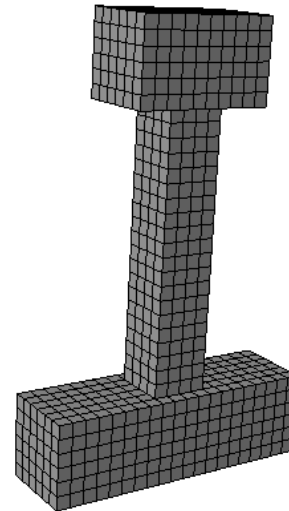

Figure4. Column with sectional dimensions of 20x20 cm created in computer program

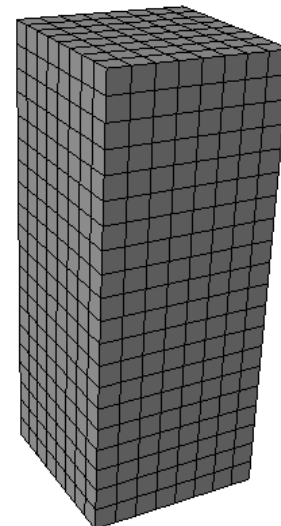

Figure5. Column with sectional dimensions of 40x40 cm created in computer program

3- ANALYTICAL MODELS

In order to verify the computer modeling and analytical results, the Control specimen which was described before, was modeled in the finite element program and subjected to the lateral and axial load. The experimental observation on this specimen is also available from the previous studies [6].

The following denominations are adopted for the specimens designed for the parametric studies. $F_c(m)-f$ or $s(n)$ in which “m” refers to the concrete compressive strength, “f” or “s” shows if the column is reinforced with longitudinal steel rebar(s) or FRP rebar(f) and the diameter of rebar is placed instead of (n).

3-1- VERIFICATION

Since the cyclic lateral load was applied to the column in the experimental work and in this study, the column is subjected to monotonic lateral load, the base shear force-displacement curve obtained from the finite element program is compared with envelope of base shear force-displacement curve of the experimental work.

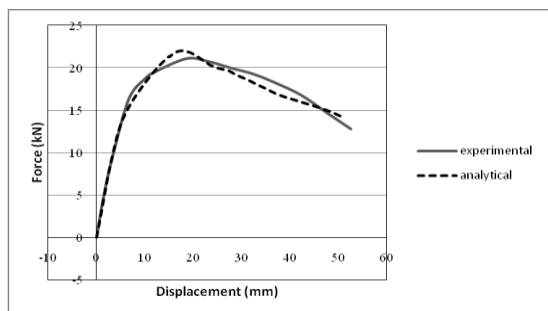

Figure6. Base shear force-displacement curves obtained from finite element program and experimental work

As it can be seen from the graph, the initial stiffness of two curves are very close to each other and also the softening branches are similar.

3-2- EFFECT OF FRP BARS RATIO ON CONCRETE COLUMNS BEHAVIOR

Investigating 6 specimens with different ratio of CFRP bars showed that increasing the ratio of CFRP bars enhanced the column strength and also increased the ultimate displacement of columns (ultimate displacement occurred when strain in CFRP bars reached the rupture strain).

3-3- EFFECT OF CONCRETE STRENGTH ON BEHAVIOR OF CONCRETE COLUMNS STRENGTHENED WITH FRP BARS

Analyzing four specimens with different concrete compressive strengths showed that by increasing concrete compressive strength, the flexural capacity of columns was enhanced but on the other hand, the ultimate displacement of column decreased considerably.

3-4- EQUIVALENT CFRP BAR RATIO WITH STEEL REINFORCEMENT RATIO IN COLUMNS

In this section, three concrete columns reinforced with steel rebar were modeled in the finite element program. In order to find an equivalent CFRP bar ratio, which leads to the same column strength, steel reinforcement was then replaced by CFRP bars with various diameter. The Specimen properties are given in the table below.

Table2. Specimen properties

specimen	Section dimension (cmxcm)	Height of column (m)	Longitudinal rebar	Rebar percentage (%)	compressive strength of concrete (MPa)
fc40-f6	40x40	1	CFRP	0.21	40
fc40-f8	40x40	1	CFRP	0.38	40
fc40-f10	40x40	1	CFRP	0.59	40
fc40-s10	40x40	1	STEEL	0.59	40
fc40-s12	40x40	1	STEEL	0.85	40
fc40-s14	40x40	1	STEEL	1.15	40

Force – displacement curves obtained from the analysis indicates that replacing CFRP bars instead of steel rebars in columns to achieve the same strength led to the use of CFRP bars with the lower diameters or in other words , the ratio of CFRP reinforcement to the ratio of steel reinforcement in a same strength is significantly less.

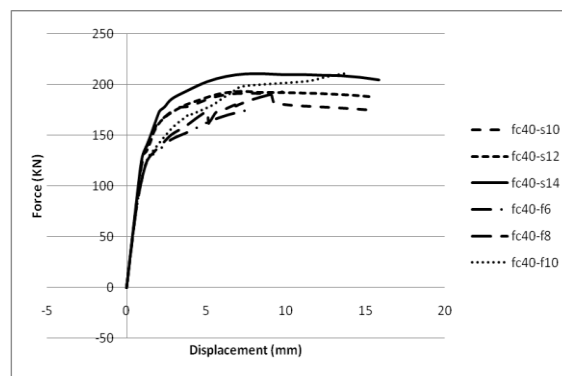

Figure7. Base shear force-displacement curves of specimens

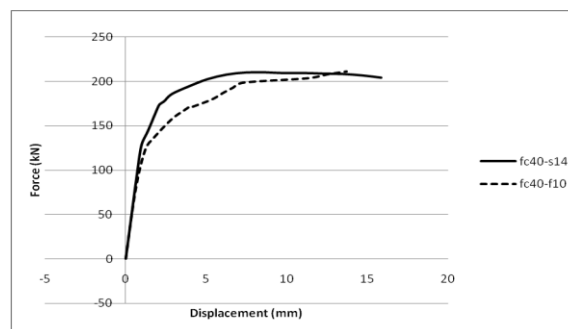

Figure8. Base shear force-displacement curves of columns with CFRP bars reinforcement ratio of 0.59 and steel reinforcement ratio of 1.15%

According to the results obtained from this study, we can use lower percentage of FRP bars in column cross section compared to steel rebar percentage to reach the same strength. Using FRP bars to design concrete columns in addition to reducing structural weight, prevent steel corrosion and deterioration of concrete especially in the structures near seashore, bridges piers etc.

4- CONCLUSIONS

In this paper, to evaluate the effect of replacing steel rebar with CFRP bars, column specimens reinforced with CFRP bars were modeled in the finite element program. The effects of parameters such as ratio of longitudinal CFRP reinforcement and concrete strength on the base shear force and ultimate displacement of columns were then investigated. To be continued, the equivalent CFRP bar ratio needed to be replaced instead of steel rebar to reach the same column strength was found.

The results obtained from studies can be summarized as follows:

- In column specimens with constant concrete strength, increasing CFRP bars ratio enhanced the column flexural strength and also increased the ultimate displacement of column.
- In column specimens with constant CFRP bar ratio, increasing concrete compressive strength, enhanced the flexural capacity of columns but on the other hand, the ultimate displacement of column decreased.
- For designing columns, steel rebar can be replaced by the lower ratio of CFRP bars in section to reach the same strength. Using FRP bars to design concrete columns in addition to reducing structural weight, prevent steel corrosion and deterioration of concrete especially in the structures near seashore, bridges piers etc.; however, it should be noted that the columns with CFRP reinforcement can tolerate less ultimate displacement.

5- REFERENCES

[1] Alkhrdaji, T. & Nanni, A., "Flexural strengthening of bridge piers using FRP composites", center for infrastructure engineering studies (CIES), university of

Missouri-Rolla, 1999.

- [2] Bournas, D.A. & Traintafillou, T.C., "Flexural strengthening of RC columns with near surface mounted FRP or stainless steel reinforcement: experimental investigation", The 14th World Conference on Earthquake Engineering, October 12-17, Beijing, China, 2008.
- [3] Bournas, D. A., Lontou, P. V., Papanicolaou, C. G. & Triantafillou, T. C., "Textile-Reinforced Mortar (TRM) versus FRP Confinement in Reinforced Concrete Columns", ACI Structural Journal, vol. 104, pp. 740-748, 2007.
- [4] Triantafillou, T. C., Papanicolaou, C. G., Zissimopoulos, P. & Laourdekis, T., "Concrete Confinement with Textile-Reinforced Mortar Jackets". ACI Structural Journal, vol. 103, PP. 28-37, 2006.
- [5] Barros, J. A.O., Varma, R. K., Sena-Cruz, J. M. & Azevedo, A. F.M., "Near surface mounted CFRP strips for the flexural strengthening of RC columns: Experimental and numerical research", Engineering Structures, vol. 30, pp. 3412-3425, 2008.
- [6] Sarafraz, M. & Danesh, F., Flexural Strengthening of RC columns with NSM rods. PhD thesis, University of KNT, Tehran, Iran, 2010.
- [7] Guide for the Design and Construction of Concrete Reinforced with FRP Bars Reported by ACI Committee 440, American concrete institute.