



Study of Cyclic Behavior of Moment Connection of Beam to Built-up Box Column with Welded Flange Plates and Vertical Rib Plates

A. Deylami^{1*}, A. Tolou Kian²

1- Associate Professor, Department of Civil & Environmental Engineering, Amirkabir University of Technology, Tehran
2- M.Sc. Student, Department of Civil & Environmental Engineering, Amirkabir University of Technology, Tehran

(Received 05 Mar 2011; Accepted 15 Jun 2014)

ABSTRACT

This paper presents a study on moment connection of I-beam to built-up box column using flange plates. In this type of connection, the beam flanges are not connected to the column flange directly. The flange plates are fillet welded to the beam flanges and CJP groove welded to the column flange. To investigate the cyclic behavior of the connection, nonlinear finite element program ABAQUS 6.8.1 is used. Results show that stress in the groove weld between beam flange plates and column flange is high which results in potential of brittle fracture and non-ductile behavior of the connection. To reduce the stress in the groove weld, single and double trapezoidal rib plates are installed on each beam flange plates. The rib plates are groove welded to the column flange and fillet welded to beam flange plates. Results of finite element analysis show that use of the rib plates although have no significant effect on global behavior of the connection but they result in reduction in the stress in the groove weld between beam flange plates and column flange.

KEYWORDS

Moment Connection, I-Beam, Built-up Box Column, Cyclic Behavior, Trapezoidal Rib Plates.

* Corresponding Author, Email: Deylamia@aut.ac.ir

1- INTRODUCTION

This paper presents numerical studies on the cyclic behavior of moment connection between I-beam and built-up box column. The connection utilized the welded flange plates (WFP) to connect the beam flanges to the column flange, instead of the direct connection of the I-beam to the column flange. The connection of the flange plates to column flanges was done using CJP groove weld. The flange plates were fillet welded to the beam top and bottom flanges. The continuity plates were installed inside the column at the level of the top and bottom beam flange plates. The geometry of the conventional welded flange plate moment connection of I-beam to built-up box column is illustrated in Figure 1.

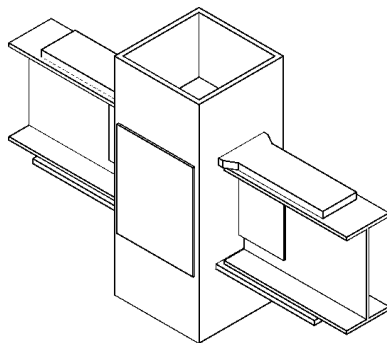

Figure 1: Conventional moment connection of I-beam to built-up box column

2- METHODOLOGY

To evaluate the behavior of the conventional moment connection, a numerical analysis was carried out on a model of two sided moment connection subassembly. The finite element ABAQUS 6.8-1 program was used to model the connection.

Distributions of the normalized longitudinal stress at 0.04 rad. interstory drift angle, along the width of beam top and bottom flange plate at the location of the CJP weld, were plotted in Figure 2 (Figure 2a for the top flange plate and Figure 2b for bottom flange plate). The normalized longitudinal stress was defined as the longitudinal stress, S_{xx} , divided by the nominal strength of the weld metal per unit area, F_w . Since E60 electrode was considered for CJP weld, hence F_w was equaled 420 MPa.

As shown in Figure 2a, the stresses were concentrated on the center of the top flange plate due to the special widened shape of this plate near the column. The inclined outer parts of the top flange plate are not stiff and transfer the small amount of force. The stress at the intersection of bottom flange plate and column flange distribute in a different pattern. The stresses were concentrated on both edges of the bottom flange plate due to the stiffness provided by the webs of the box column which were located on both sides of the flange plate.

3- UPGRADING OF THE CONVENTIONAL CONNECTION

In order to reduce the stress concentration on the CJP weld between flange plates and column flange, the connection was reinforced by vertical top and bottom rib plates which were groove welded to the column flange and fillet welded to the beam flange plates. Two types of models for upgrading with vertical rib plates, namely model with single rib and model with double ribs, were considered.

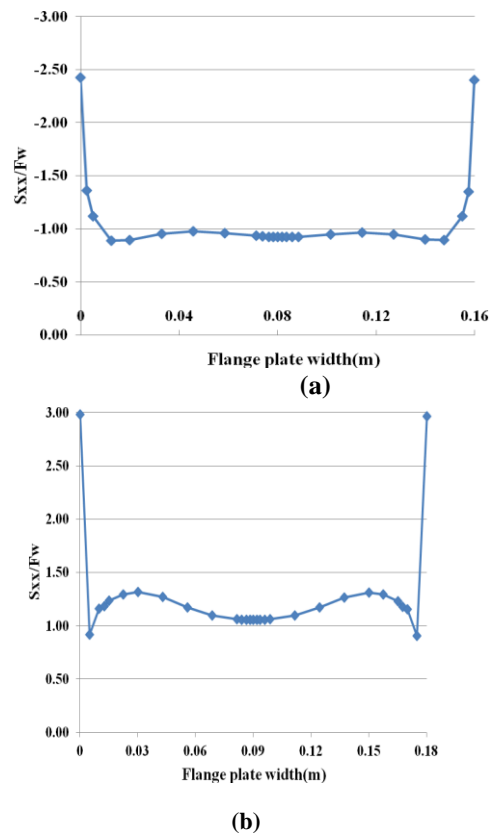

Figure 2: Stress distribution at CJP weld a) Top flange plate b) Bottom flange plate

As shown in Figure 3, in the models reinforced by the vertical rib plates, the stress level on the CJP weld between flange plates and column flange was reduced and the stress distribution became relatively uniform. The difference between the stress distribution in the models with double ribs and single rib was negligible.

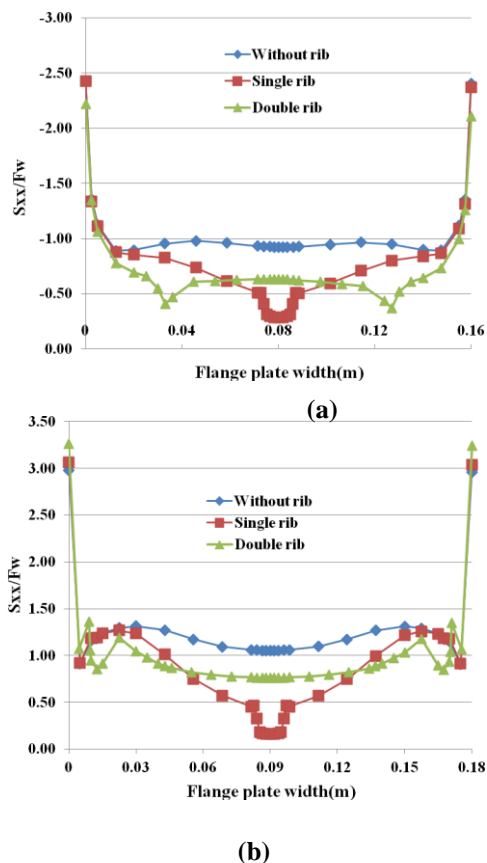

Figure 3: Stress distribution at CJP weld a) Top flange plate
b) Bottom flange plate

4- REFERENCES

- [1] Chen, C. C.; Lin, C. C.; Tsai, C. L. ,“Evaluation of reinforced connections between steel beams and box columns”, Engineering Structures, vol. 26, p.p. 1889–1904, 2004.
- [2] Chen, C. C.; Chen, S. W.; Chung, M. D.; Lin, M. C. ,“Cyclic behavior of unreinforced and rib-reinforced moment connections”, Constructional Steel Research, vol. 61, pp. 1–21, 2005.

- [3] Federal Emergency Management Agency, FEMA-350: Recommended seismic design criteria for new steel moment-frame buildings, SAC Joint Venture, Sacramento, California, 2000.
- [4] AISC, American Institute of Steel Construction, Specification for structural steel buildings, Chicago, 2005.
- [5] Hibbit; Karlsson; Sorenson; ABAQUS Theory Manual, Pawtucket, RI, 2008.
- [6] Mazzolani, F. M.,“Moment Resistant Design of Steel Frames in Seismic Areas”, 1st Edition, E & SPON, 2000.