



Evaluation of seismic behavior of eccentric braced dual steel frames equipped with shape memory alloys

M. Bagheri¹, S. A. Hosseini², A. Vedad³

¹ Department of Civil Engineering, Birjand University of Technology, Birjand, Iran

² Faculty of Technology and Mining, Yasouj University, Choram, Iran

³ Department of Civil Engineering, Besat Institute of Higher Education, Kerman, Iran

Review History:

Received: Sep. 19, 2020

Revised: Jan. 29, 2021

Accepted: Jun. 25, 2021

Available Online: Jul. 03, 2021

Keywords:

Dual steel moment-resisting frame

Chevron eccentric brace

Shape memory alloy

Residual displacement

Non-linear dynamic time history analysis

ABSTRACT: Due to the suitability and ductility of the eccentric bracing system, the effect of reversible materials such as shape memory alloys in reducing the residual displacement at the end of the earthquake is studied. Moreover, seismic evaluation of eccentric bracing dual steel bending frame structures within 5, 10, and 15-stories equipped with shape memory alloy rods were subjected to the non-linear dynamic time history analysis. Maximum absolute displacement of the roof and relative displacement of stories, the maximum residual displacement of the roof, maximum base shear, and roof acceleration in the desired frames were evaluated and compared. Survey results showed that the absolute and relative inter-story drift in all three models due to the lower elastic modulus of shape memory alloys has been greater than models without shape memory alloys. On the other hand, the values of residual displacement, shear stories, and acceleration of the roof of structural models have shown a sudden sharp drop compared to models that have not been equipped with shape memory alloys. Comparison of structural responses in different models also showed a further reduction effect on the plastic displacement of the 5-stories model, base shear, and roof acceleration of 10 and 15-stories structures.

1- Introduction

One of the intelligent structural controllers is shape memory alloys (SMAs) that have been widely used in engineering and medical sciences. One of the main applications of SMAs is to inhibit the displacement of waste plastics due to their properties, such as high damping capacity, durability, and resistance to fatigue and corrosion. So that by increasing the damping of the structure and seismic energy dissipation, forces, and displacement, Earthquake-generated debris is significantly reduced in the structural building, while it is usually not possible to reduce them at the same time in traditional retrofitting methods. SMAs are used in seismic isolation systems, energy dampers, structural joints, innovative reinforced concrete, and composites structures [1].

One of the main drawbacks of concentric bracing systems is the lack of proper inelastic deformations. So eccentric braces are used to improve the bracing behavior under alternating loads and to prevent flexural buckling. In this study, a new type of connection of SMA rod to eccentric bracing structures was modeled, and the comparative results were analyzed.

2- Methodology

In this study, dual steel moment frames with Chevron eccentric bracing system in 5, 10, and 15-stories equipped

with SMA rods (EBF-SMA) and without SMA (EBF) are modeled in SeismoStruct software [2], and non-linear dynamic time history analysis is performed. Then the maximum seismic responses, including absolute displacement of the roof, the relative displacement of stories, displacement of the roof, base shear, roof acceleration, plastic joints of the frame members, and energy absorption of the braces, were evaluated and compared.

The models include three spans of 4 meters in x and y directions with a height of each floor equal to 3.20 meters in an area with high seismicity on type soil D. AISC 2010 [3] has been used to design medium bending steel eccentric bracing frames. Seismic provisions such as drift ratios and application of load combinations 100% in the main direction and 30% in the orthogonal direction are controlled according to the Iranian Code of Practice for Seismic Resistance Design of Buildings: Standard No. 2800. The behavior of applied steel is a bi-line type according to the characteristics defined in SeismoStruct software, which is known as `stl_bl` and has a coefficient of elasticity and yield strength of 2×108 and 24×104 kPa, respectively, while the cinematic strain hardness is 0.005. For SMAs, a coefficient of elasticity of 27,600 MPa is considered. This coefficient is approximately seven times lower than the elasticity of steel, which has a significant effect on the structural responses.

*Corresponding author's email: mnsrbagheri@birjandut.ac.ir



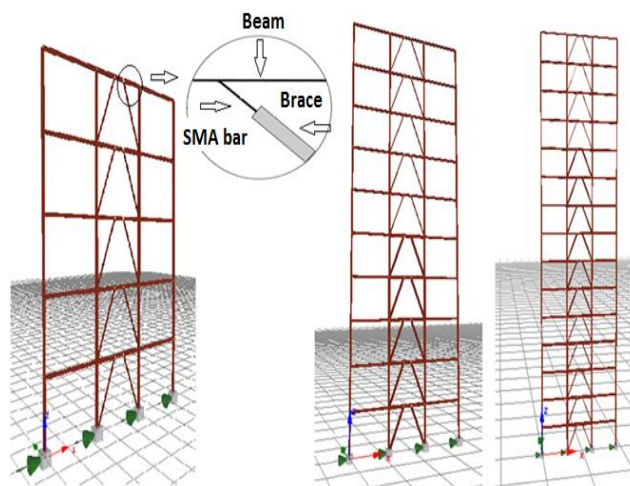

Fig.- 1. Structural models in SeismoStruct software

Applied earthquake records are away from the fault on type soil D and in a region with a high seismic hazard that have been selected from Table C-3 of FEMA440 [4]. Figure 1 depicts a schematic view of structural models equipped with SMA generated in SeismoStruct software.

2- 1- Verification

In order to verify the accuracy of the structural modeling in SeismoStruct software, an experimental model adopted by Xu et al. [5] has been selected that a reverse Chevron bracing system is subjected to a cyclic lateral load. The frame is equipped with post-tensioned cables and SMA rods. The steel of the members is A572 Grade 50 in I-shape. High-strength cables with a diameter of 15 mm are pulled back in the middle of the height of the link beam, and 4 SMA rods with a diameter of 30 mm are located symmetrically at the junction of the link beam. The dimensions of the sections used for the column, beam, and brace are shown in Figure 2.

The comparative hysteresis curves of the SeismoStruct modeling and the experimental are plotted in Figure 3, which shows the acceptable accuracy of the model made in the software.

3- Results and Discussion

Survey results indicated application of SMA in the Chevron bracing increases the absolute displacement compared to the structure without SMA. One of the reasons for this increase is the low coefficient of elasticity of SMA alloys compared to steel, leading to reduced structural stiffness. Based on the results of structural responses, it was found that the absolute displacement ratio of the models with SMA to models without SMA is 1.7. Also, this ratio is equal to 3.1, 2.1, and 1.9 for relative inter-story displacement in 5, 10, and 15-stories structures, respectively. So, high-rise structures with SMA alloys have a smaller increase in relative displacement than short-rise ones, creating a better situation for the structure in operating conditions and the safety of residents.

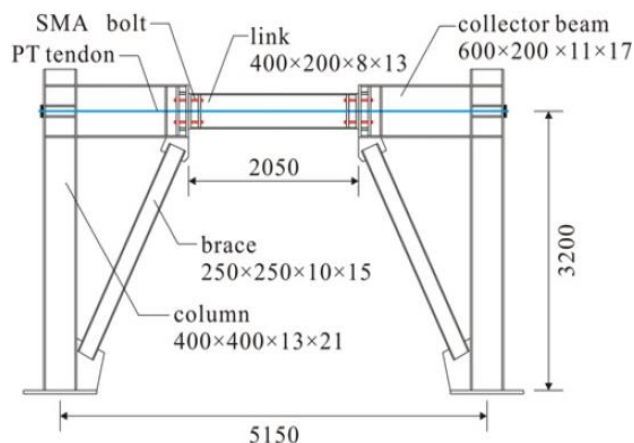

Fig. 2. Zhou et al. experimental model [5]

The diagrams of maximum residual displacement for all accelerograms at the end of the effective earthquake time showed that models with SMA could return to their original state and increase energy absorption after withstanding a significant strain. So that the average maximum displacement of all earthquake records in 5, 10, and 15-stories SMA equipped models was about 67.5%, 59.2, and 57.9% less than structures without SMA, respectively. That indicates the excellent performance of SMA-equipped structures in reducing earthquake damage to structural members and greatly reduces the cost of repairs and reconstruction.

The base shear created in the SMA structures is reduced under seismic loading compared to conventional structures. That is due to the increase in the time and softness of SMA-equipped models compared to conventional structures, reducing the seismic forces in the bracing elements. The average reduction of base shear for 5, 10, and 15-stories equipped SMA structures compared to models without SMA is 47.4%, 48.9%, and 56.1%, respectively.

Comparison of maximum acceleration reduction on the roof of structures with and without SMA is equal to 50.8, 58.6, and 43.4% in 5, 10, and 15-stories, respectively, which could cause in reducing the base shear.

The value of residual displacement, base shear, and roof acceleration for 5-stories structures has decreased more than the corresponding values of 10 and 15-stories.

Comparing the cyclic curves of SMA models, it is clear that the presence of SMA reduces the energy absorption of the bracing system and thus reduces the cross-section of the brace and the connection beam that, on average, 2.36 % of the earthquake energy is absorbed by the SMA.

Due to the ultra-elastic properties of SMA, story shear, roof acceleration, and stiffness of the structure were increased in the period time, while residual displacement values have decreased significantly.

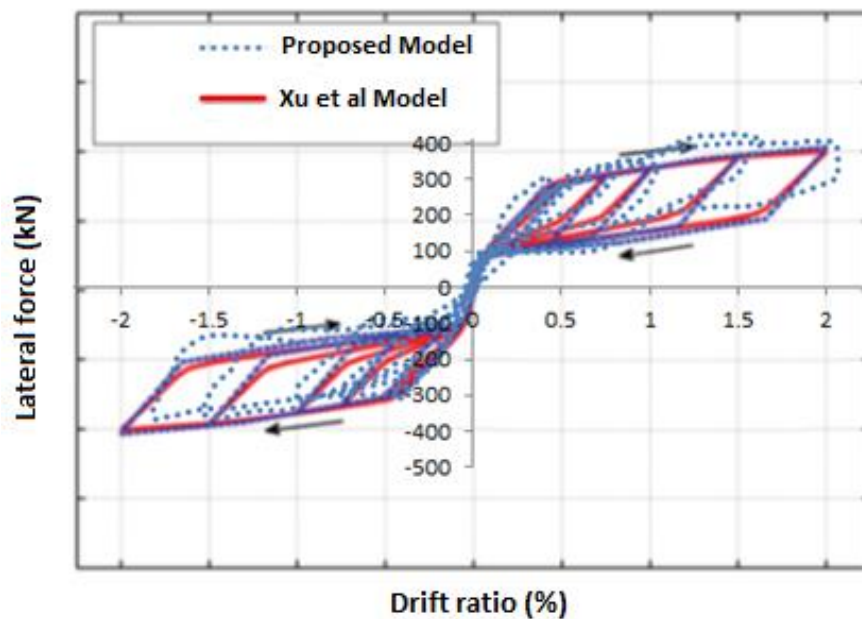

Fig. 3. Experimental and SeismoStruct hysteresis curves

4- Conclusion

In this study, 2-D dual moment steel with Chevron bracing models was generated in SeismoStruct software, that at the end of the braces, SMA rods were used. The structures were subjected to the non-linear dynamic time history analysis, and the structural responses such as maximum absolute roof displacement, maximum relative floor displacement, maximum roof displacement, maximum base shear, and maximum roof acceleration were evaluated and compared. A comparison of the results showed that SMA-equipped high-rise structures showed a slight increase in relative inter-story displacement, which provides more suitable conditions in operation conditions.

References

- [1] G. Song, N. Ma, H.-N. Li, Applications of shape memory alloys in civil structures, *Engineering structures*, 28(9) (2006) 1266-1274.
- [2] SeismoSoft, SeismoStruct—a computer program for static and dynamic non-linear analysis of framed structures [online], in, 2006.
- [3] A. Committee, Specification for structural steel buildings (ANSI/AISC 360-10), American Institute of Steel Construction, Chicago-Illinois, (2010).
- [4] A. Fema, 440, Improvement of non-linear static seismic analysis procedures, FEMA-440, Redwood City, 7(9) (2005) 11.
- [5] X. Xu, Y. Zhang, Y. Luo, Self-centering eccentrically braced frames using shape memory alloy bolts and post-tensioned tendons, *Journal of Constructional Steel Research*, 125 (2016) 190-204.

HOW TO CITE THIS ARTICLE

M. Bagheri , S. A. Hosseini, A. Vedad , Evaluation of seismic behavior of eccentric braced dual steel frames equipped with shape memory alloys, *Amirkabir J. Civil Eng.*, 54(2) (2022)
M. Bagheri et al., *Amirkabir J. Civil. Eng.*, 54(2) (2022) 133-136,

DOI: 10.22060/ceej.2021.19030.7038



